

# AETES

## 220VDC INVERTER 1PH

*Internal Isolation Transformer  
Industrial-Grade Enclosure  
Advanced User Panel*

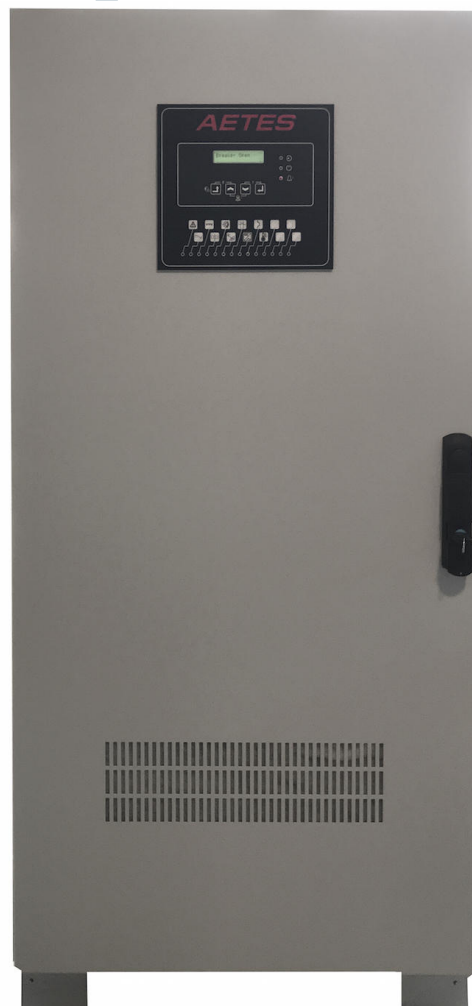

*"...power alliance..."*

## DESCRIPTION

AETES DC to AC Inverter is a high technology equipment, including all protection and control systems, which is designed and manufactured to convert an DC voltage to pure sinus and regulated AC voltage with a predefined frequency. It provides AC power, which is especially important for Industrial, Telecom and Defence applications.

This equipment contains an output isolation transformer, it provides full electrical isolation between DC input supply and AC output, and uses all advantages of Digital Signal Processor control. It provides handy user interface and advanced communication features.

## FEATURES

- Single Phase Full Sinus AC Output
- Internal Isolation Transformer at Output
- Full Bridge IGBT / IPM / Mosfet Inverter Block
- Smart Control and High Reliability With Digital Signal Processor
- Low Output Voltage Harmonics
- High Efficiency
- Wide DC Input Range
- Functionality at Low DC Voltages
- LCD Display Front Panel, Showing Measurements, Status and Alarm Messages
- Led Displays and Audible Alarm for Easy Observation of Inverter Status
- Calibration of Measurements from Front Panel
- Language Selection from Front Panel
- DC Low / High / Too Low, Over Temperature, Short Circuit protections
- Battery Deep Discharge Protection
- Ability to program all operation parameters (password protection)

# GENERAL SPECIFICATION

Models:      220-230-20K      220-230-30K      220-230-40K

## DC Input

Voltage	182V...272V DC
Protection	Fuse and DC Breaker
Efficiency	>85% (full linear load), 220VDC I/P, 220VAC O/P

## AC Output

Capacity	20kVA / 16kW	30kVA / 24kW	40kVA / 32kW
Voltage	220V/ 230V/ 240V AC		
Voltage Regulation	±2%		
Frequency	50Hz / 60Hz ± 0.2Hz		
Wave Form	Pure Sine Wave		
THD (linear load)	3% 220 V/100%		
THD (SPS load)	5% 220 V/100%		
Crest Factor	3:1		

## Bypass

Voltage	Nominal 230 VAC
Frequency	50/ 60 ± 5 Hz
Protection	AC Circuit Breaker

## Protection

Short	For 1 second; Switch to Bypass, then shutdown
Overload	105-125% for 3 seconds >125% for 1 second; Switch to bypass

Temperature Range	-10°C... 50°C
-------------------	---------------

## Compatibility

Safety	IEC60204
EMC/ EMI/ RFI	IEC61000

## Mechanical

Dimensions (mm)	A:620 B:620 C:1300	A:620 B:620 C:1300	A:800 B:800 C:1600
-----------------	--------------------	--------------------	--------------------

## OPTIONS

- Input DC Filter Module
- Parallel Operation Card up to 4 devices
- By-Pass Isolation Transformer
- Analog Gauges (Input / Output / Voltmeter and Ammeter)
- Transducers for Input / Output Voltage / Current (4-20mA and 0-10V)
- DC Earth Leakage Monitoring
- Powermeter for Output Power Factor / kVA / kW measurement
- Programmable Dry Contact Relay Boards (Max 3 pcs, 12 relays)
- Internal Cabinet Heater
- Communication Interface: ModBus RS232, RS485, TCP IP, MQTT

## BLOCK DIAGRAM

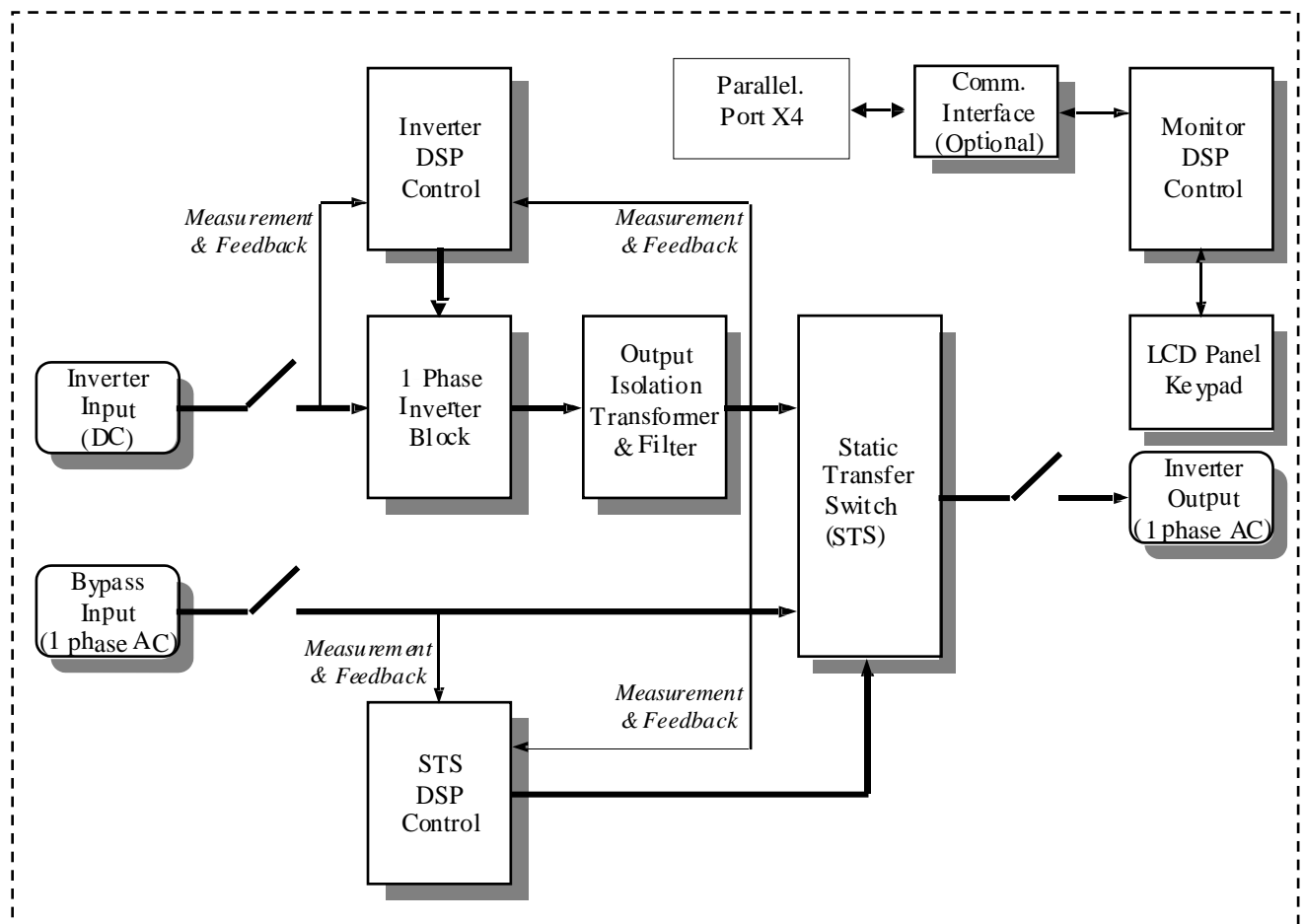

AETES Industrial Inverter 1PH Output Block Diagram

# DRAWING

FRONT

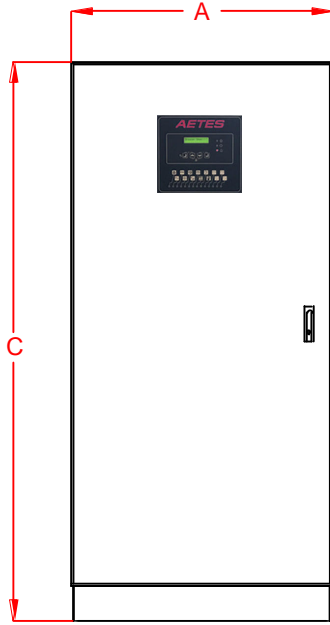

LEFT

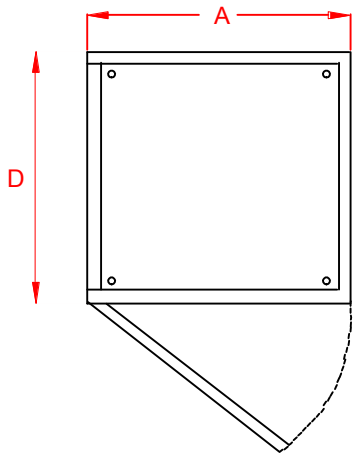
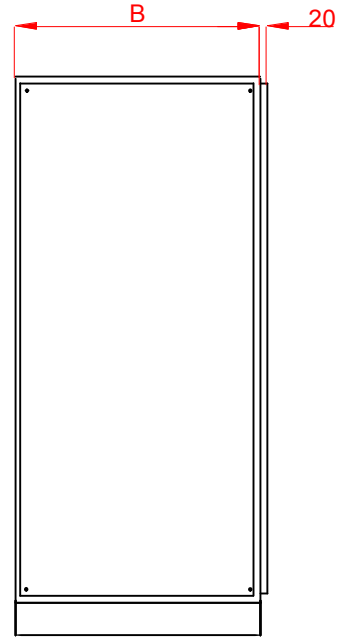

TOP

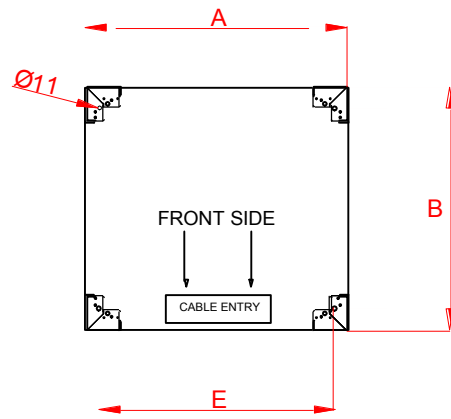

BOTTOM

*"...power alliance..."*

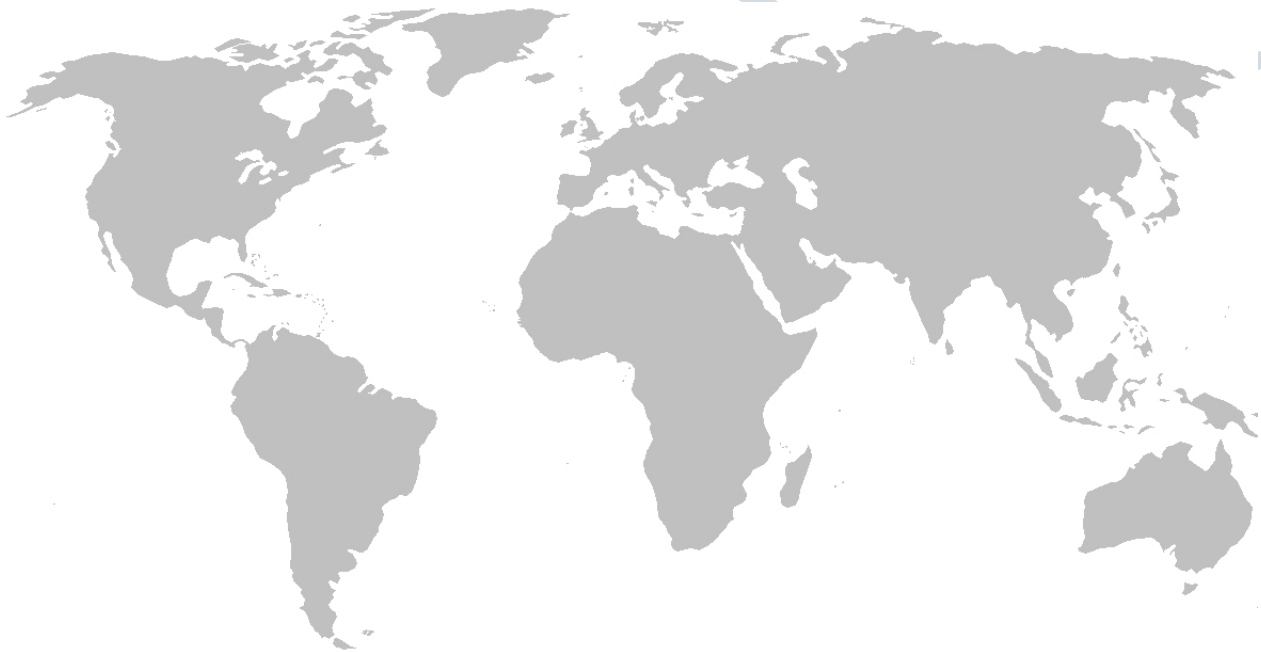

**AETES**  
*"...power alliance..."*

The specifications, drawings and images indicated in this document are based on current information. All content is subject to modifications or additions. For more information on our local sales offices, visit us at our website below.