

# AETES

**3PH 28VDC PSU 2800-4200W**

*Power Boost of 150% for 5s  
Industrial Grade Design  
Five Year Warranty*



*"...power alliance..."*

## Specification

ITEMS	MODEL	XPM-3P4-028-2K8	XPM-3P4-028-4K2
Output Voltage		28VDC	
Max. Output Current (DC)		100A (2800 Watt)	150A (4200 Watt)
Input Voltage Range		3-Phase 380V/ 400V/ 415V AC 50/60 Hz (47..63Hz)	
Input Current Typ. (400V AC)		3x 7A (Cold Start Inrush; max.60A)	3x 10A (Cold Start Inrush; max.60A)
Output Power Reserve		150% peak load for 5 seconds at <25°C	
Power Factor		0.9 (Meets EN61000-3-2 Class A)	
Overcurrent Protection		>105-150% Constant current style	
Overvoltage Protection		125% -140%	
Hold Up Time (Typ)		20ms	
Efficiency (400V AC)		<88%	
Load Regulation (max.)		150 mV	
Line Regulation (max.)		100 mV	
Ripple Noise (max.)		200 mV	
Remote On/Off		Yes	
Power Good /Alarm Contact		Dry Contact (NO/ NC)	
Status Indicator LED		White: OFF   Blue: READY   Green: ON   Red: FAULT	
Enclosure Color		Grey (RAL7035)	
Operating Temperature		-20°C to 70°C, derating linearly to 50% load above 50°C	
Storage Temperature		-30°C to +75°C	
Humidity (non condensing)		30- 90% RH operating, 10-90% RH non operating	
Cooling		Internal fan	
Withstand Voltage (One minute)		Input to Ground 2kVAC, Input to Output 3kVAC, Output to Ground 500VAC	
Isolation Resistance		>100MΩ at 25°C & 70%RH, Output to Ground 500VDC	
Vibration Compatibility		MIL-STD-810F 514.5 CAT. 4,10	
Shock Compatibility		<196.1 m/s <sup>2</sup>	
Immunity Compatibility		EN61000-4 -2 -3 -4 -5 -6 -8 -11	
Safety Compatibility		EN60950-1	
EMI Compatibility		EN55011 / EN55022-B, FCC Class B	
Weight (Typ)		13,3 kg	17,5 kg
Dimensions (mm)		F:150 B:320+20 C:315	F:150 B:320+20 C:420
Warranty		5-YEAR	

Drawing

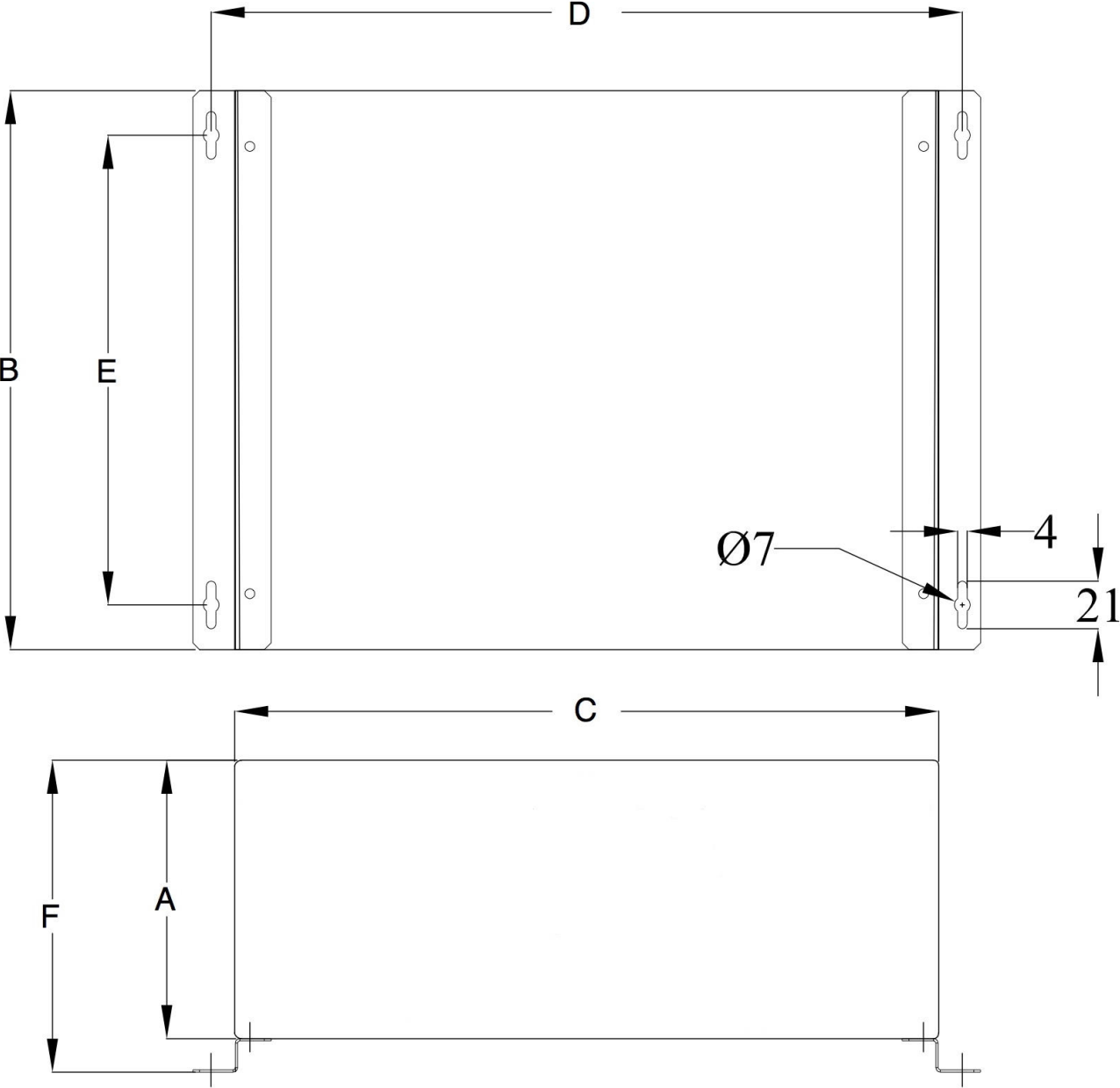

*"...power alliance..."*

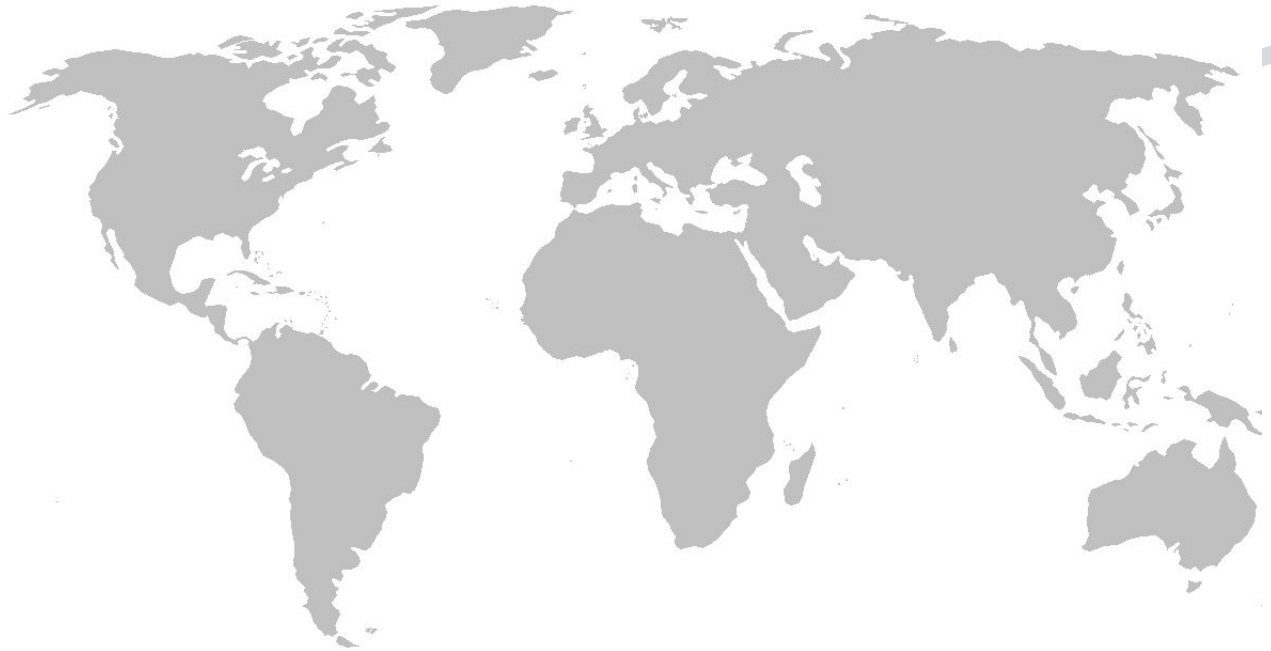
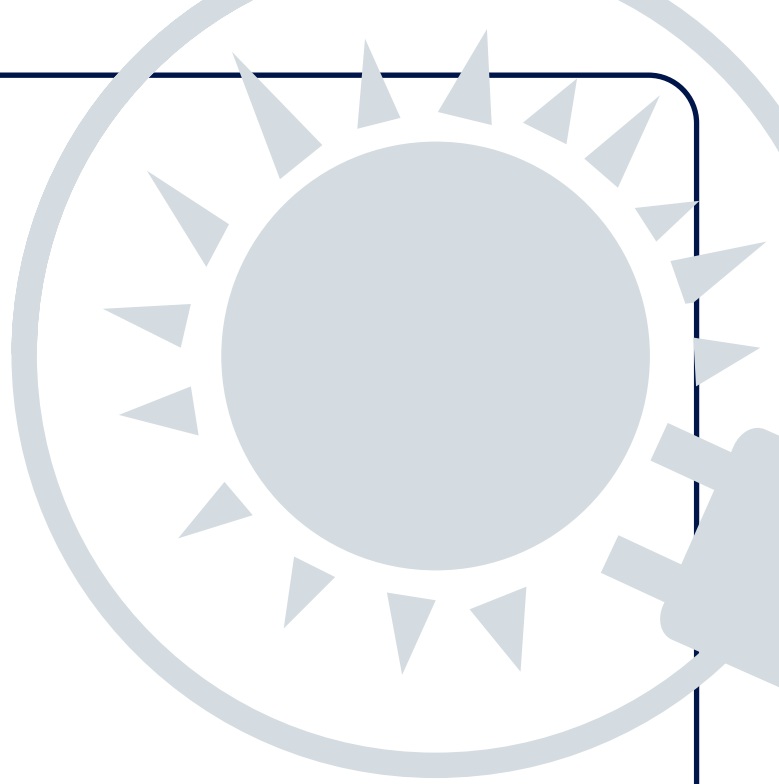

**AETES**  
*"...power alliance..."*

The specifications, drawings and images indicated in this document are based on current information. All content is subject to modifications or additions. For more information on our local sales offices, visit us at our website below.