

AETES

Rectifier Charger 125V 40A-80A

Internal Isolation Transformer

Industrial-Grade Enclosure

Advanced User Panel



"...power alliance..."

DESCRIPTION

AETES XFM Series SCR-based Industrial Rectifier Charger is a high-technology piece of equipment, including all protection and control systems, which is designed and manufactured to convert 3-Phase AC voltage to pure regulated 125V DC voltage. It provides DC power, which is especially important for industry and energy applications. When this system is used with a battery group at its output, this equipment charges batteries and acts as a Uninterruptible DC Power Source.

This equipment contains an input isolation transformer and provides full electrical isolation between input supply and 125 Volt DC output.

This uses all advantages of Digital Signal Processor control. It provides handy multilingual user interface, and automation compatible communication features. When used as battery charger, it can perform battery charge in 3 different modes: Float Charge, Equalizing Charge, Boost Charge.

FEATURES

- Internal Isolation Transformer at Input
- Active parallel current sharing operation up to 4 devices
- Soft Start, Smart control and high reliability with Digital Signal Processor
- Float charge, equalizing charge and boost charge modes
- Automatic and manual charge modes
- Low output voltage ripple and high reliability
- User panel with LCD display, showing measurements, status and alarm messages
- Audible alarm and Led displays for easy observation of Rectifier status
- Programmable current limitation
- User language selection from front panel (DE, EN, ES, NL, PT, TR)
- Calibration of measurements from front panel
- DC Low, DC High, Line Failure, Over Temperature, Short Circuit protections
- Ability to program all operation parameters (Password Protected)
- Programmable alarm relay contact outputs (4 standard, up to 16 relays as option)
- Low Voltage Disconnect (LVD) Protection
- Modbus RTU RS232 Communication
- Log records with date and time stamp up the 200 events

GENERAL SPECIFICATION

MODEL :	XFM-3P2-125-040	XFM-3P2-125-060	XFM-3P2-125-080
INPUT			
Nominal Voltage	Options: 3P or 3P+N 3x190V / 3x208V / 3x220V AC (±15%)		
Nominal Frequency	60Hz (±10%)		
Power Factor (Nominal)	0.80		
ITHD	<30-35% standard (<10% at 12 pulse Optional)		
Input Protection	Thermic Magnetic Overcurrent Protection, Overvoltage Protection		
OUTPUT			
Nominal Output Voltage	125VDC		
Output Voltage Adjustment	125V...150V DC (Optional to 162.5V DC for NiCd)		
Output Current Adjustment	10-100% of Nominal Output Current		
Float Charger Voltage Range	100%-120% of Nominal Output Voltage		
Boost Charger Voltage	100% to 120% (opt.130%) of Nominal Output Voltage		
Boost Voltage (V/C)	2,40 Lead Acid Battery 1,50 NiCd Battery		
Float Voltage (V/C)	2,24 Lead Acid Battery 1,40 NiCd Battery		
Nominal Output Current	40 Amp	60 Amp	80 Amp
Max Output Current	44 Amp	66 Amp	88 Amp
Voltage Ripple / Regulation	< 1.5% / <1.0%		
GENERAL PROPERTIES			
Bost Timer	0-99.9 hours adjustable		
Cooling	Fan Forced Cooling(Standard), Natural Cooling(Optional)		
Isolation Voltage	1500 or 3000VAC input/chassis and output/chassis		
Efficiency at full load	<91%		
Protection level	IP21(Standard) to IP54(Optional)		
Cable Entry	Front Bottom (Option: Top or Rear or Side)		
Filtering	LC Filter		
Circuit Breakers	Thermic-magnetic circuit breakers for input (Standard); for Battery and Load (Optional)		
Reset Button	Used for re-operation in case of fallure of the system.		
ENVIRONMENTAL			
Acoustic Noise	45 - 65 dB (according to Power Rating)		
Storage Temperature	(-20 °C) - (+70 °C)		
Operating Temperature	(-5°C) - (+50°C)		
Relative Humidity	0 - 95% Non-condensing		
Max Altitude	1000m (-1% Power for every 100m after 1000m) Max. 4000m		
Color	RAL7035 (Standard), others (Optional)		
COMMUNICATION & PARALLELING			
Communication	ModBus RS232 (Standard), 4 Dry Contacts (Standard), RS485 (Optional), TCP IP (Optional)		
Paralleling	Active parallel current sharing up to 4		
COMPATIBILITY			
Standards	IEC62040-1, IEC62040-2, DIN 41773		

NOTE: All specifications subject to change without notice. Consult AETES's Technical Support Department for special applications. All names used above are registered trademarks of their respective owners.

OPTIONS

- 12 Pulse option to limit input current distortion
- Wide Screen HMI Touch Panel and Mimic Diagram
- Battery Temperature Compensation Module
- Analog Gauges (Input / Output / Battery Voltages and Currents)
- Transducers for Input / Output Voltage / Current (4-20mA and 0-10V)
- Load Output Voltage Dropper
- Input Power Factor / kVA / kW measurement
- Additional Dry Contact Relay Boards (Max. 3 pcs, 12 relays)
- Internal Cabinet Heater
- Additional Alarm and Communication Interface RS485/ TCP-IP

BLOCK DIAGRAM

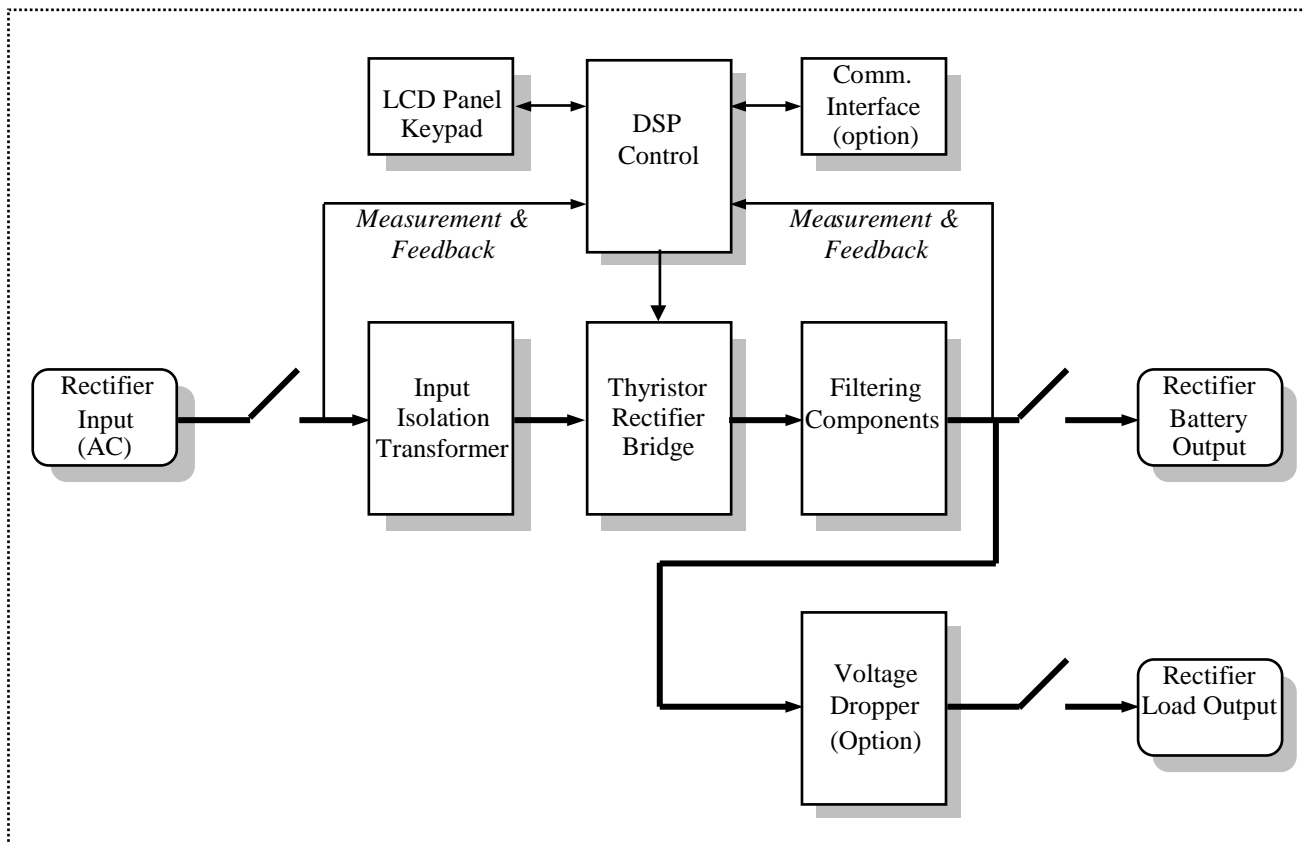

AETES XFM Series Industrial SCR Rectifier/Charger Block Diagram

LINE DIAGRAM

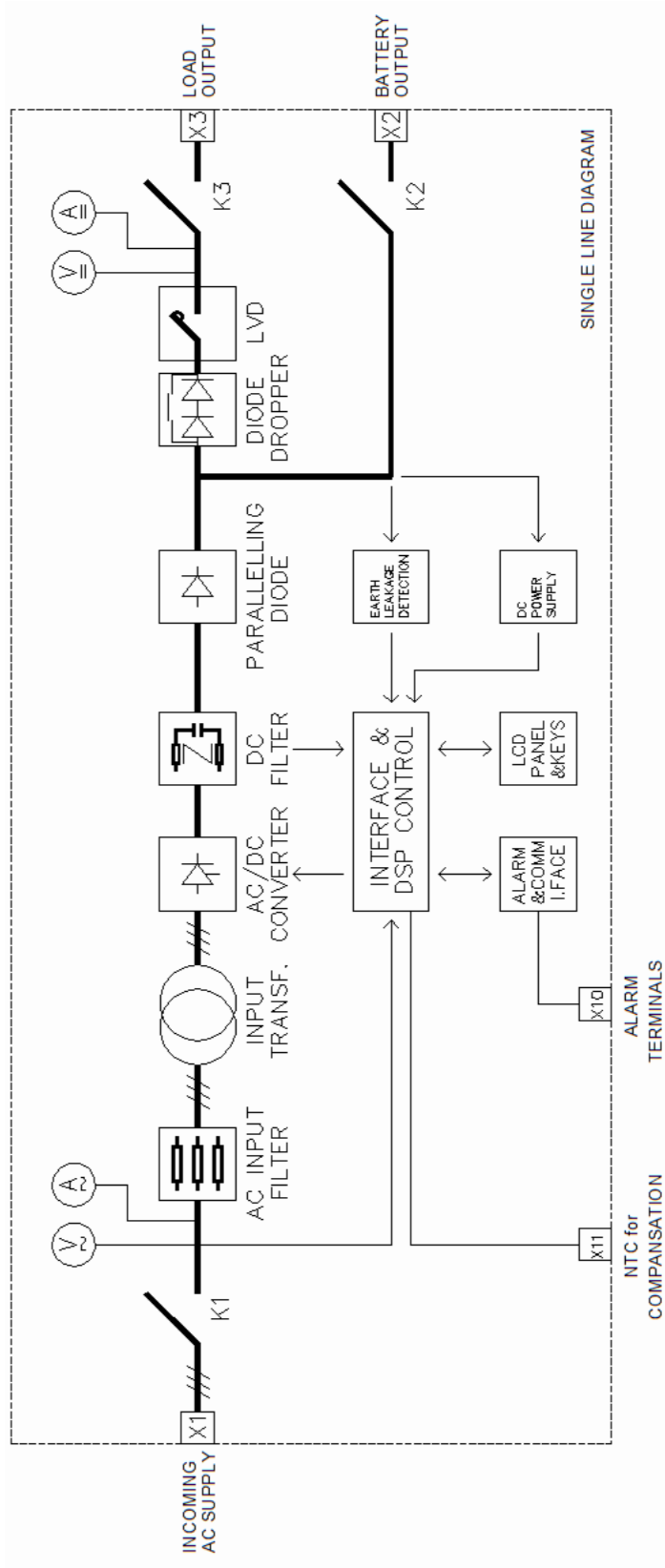

DRAWING

FRONT

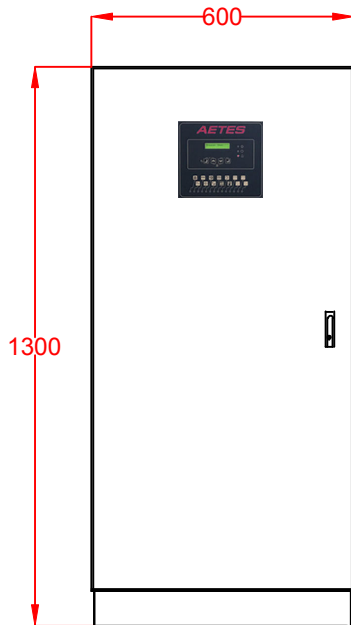

LEFT

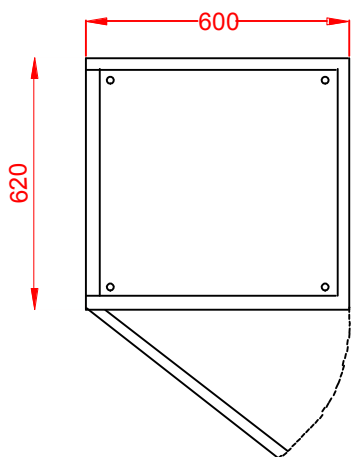
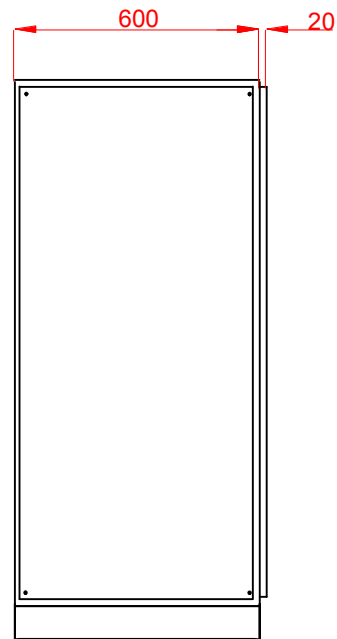

TOP

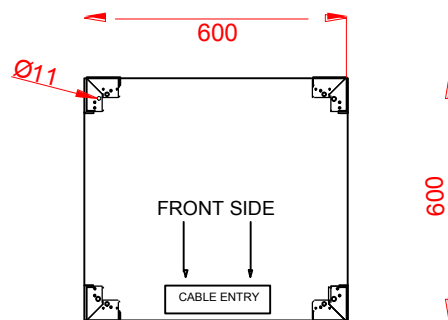

BOTTOM

"...power alliance..."

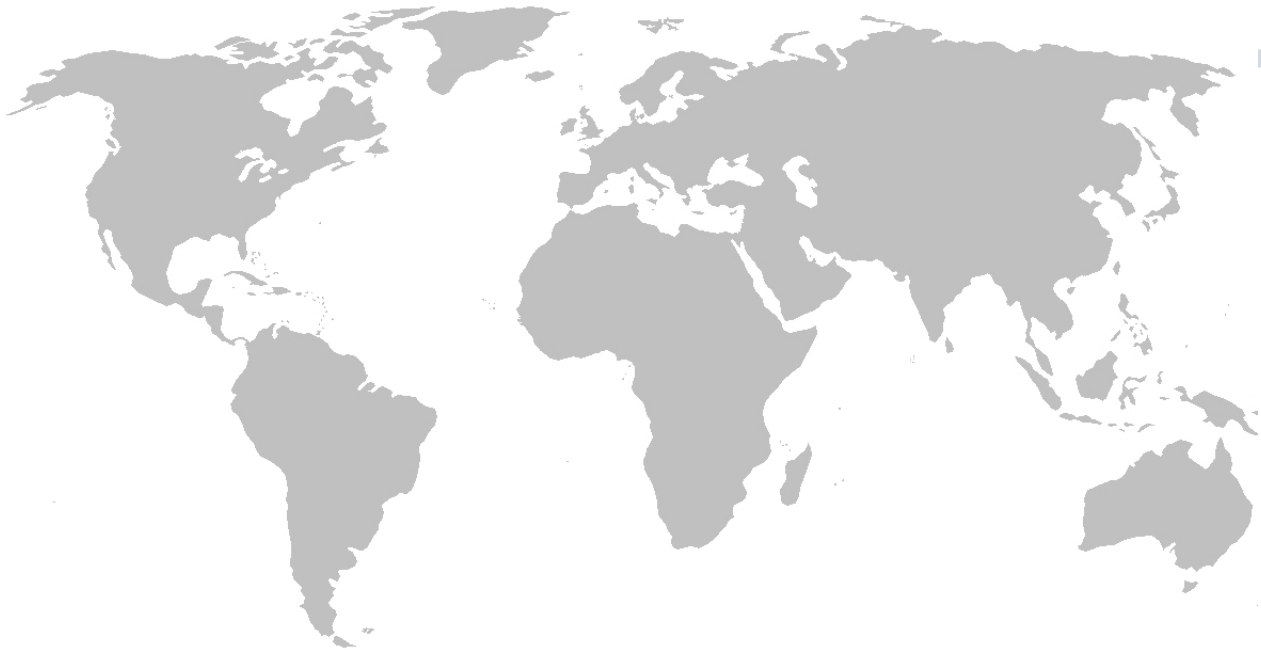

AETES
"...power alliance..."

The specifications, drawings and images indicated in this document are based on current information. All content is subject to modifications or additions. For more information on our local sales offices, visit us at our website below.